

Hitachi Submersible Motors

**For 6" and Larger
Deep Well Pumps**



For Oceania Specifications

<p>ISO 14001 EC97J1095</p>  <p>ISO 9001 JQA-1153</p>	<p>Hitachi submersible motors in this brochure are produced at the factory registered under the ISO 14001 standard for environmental management system and the ISO 9001 standard for motor quality management system.</p>
---------------------------------------------------------------------------------------------------------------------------------------------------------------	---------------------------------------------------------------------------------------------------------------------------------------------------------------------------------------------------------------------------

Certified By



The Public Health and Safety Company™

Aa1
Date : 09/09
Supersedes : 11/01

50 years of submersible motor experience

Classification of Submersible Motors

For Deep Wells

For Municipal Water Service, Industrial Irrigation and Building Water Supply

6" Canned Type

2P 3,000min⁻¹

Model : VCTI-KK (AN)
VCTI-KQ (AN)



8" and Larger Rewindable Water-Tight Type

2P 3,000min⁻¹

Model : VTI-KK (AN)



Hitachi's Special Technology

6 inch :

Canned Type



Replaceable Plug-in Type Lead

All 6" motor leads are stranded copper, extremely flexible, 3.8m (150 inches) in length and field replaceable.



Durable Insulation

The motor stator coil of the canned type is mounted in a stainless steel frame and is completely sealed in a protective stainless steel cylinder. Complete water proofing insures long life for the moisture resistant insulation.

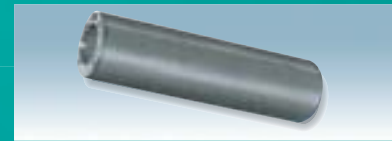

Excellent Heat Resistance

Strength against thermal fluctuation and internal mechanical stress is assured by the use of a patented "Hi-canned Resin".

The space between the stator, stainless steel protective can and frame is filled with this epoxy resin, allowing faster and greater heat dissipation resulting in longer motor life.

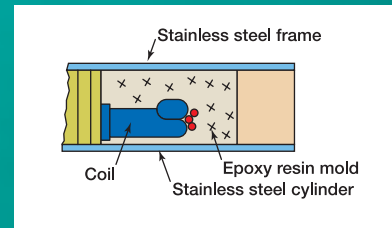

35°C (95°F) Water Temperature (5 - 40HP)

The motors operate with a flow rate 0.15m/sec. (0.5ft/sec.) in water temperature up to 35°C (95°F) without any derating of horsepower. This 35°C (95°F) temperature is 10°C (18°F) higher than NEMA standards.

8 inch and Larger :

Water Tight Type



Reliable Insulation Wire

The coil conductor insulation material is a specially developed denatured polypropylene, which offers excellent leak-resistant characteristics.

Three barriers are applied to the copper conductors to provide complete insulation against the cooling fluid inside the motor.

This design is the result of extensive research and in long insulation life under severe operating conditions.

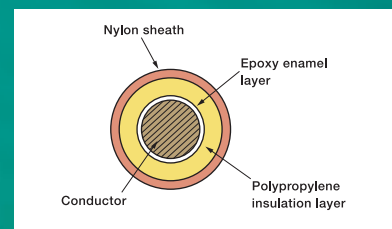

Quality Construction

The lead wires are 5m (200 inches) long and internally connected direct to the winding.

The stator is enclosed by an epoxy coated carbon steel shell, and the end bells are epoxy coated cast iron.

The cooling fluid in the motor is in direct contact with the insulated windings to help keep the motor cool.

Hitachi's General Features

High Quality Thrust Bearings

The thrust bearing is of the kingsbury type lubricated by the internal fluid. During operation a wedge of water is drawn between the stainless steel pivot shoes and carbon disc to carry the thrust load generated by the pump.

Located inside and at the bottom of the motor the bearing is sealed away from sand and other contaminants.



Sand Resistant Slinger and Lip Seals

A stainless steel slinger and slinger guide are also closely fit to help prevent sand entry.

Double rubber seals are installed to prevent well water and contaminants from entering the motor.

Rotor Core with Baked Epoxy Coating

A baked epoxy coating prevents rusting of the rotor core. All external and internal cast iron parts are coated with epoxy resin then baked for resistance to water and rust.

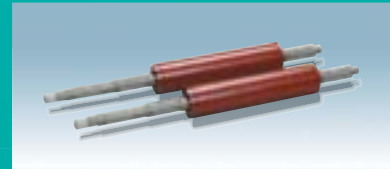

Highly Reliable Carbon Bearing

Two water lubricated carbon bearings are used as guide bearings. These have extremely large surface area and result in extra alignment support-less whipping and acts as a steady bushing.



Balancing

The rotor balance rings allow for excellent dynamic balance for the rotating element of the motor.

Water-Filled Design

The motor lubrication is provided by the internal cooling water consisting of a water, antifreeze, and antirust mixture good to -30°C (-22°F).

This mixture is installed at the factory. Two water plugs are Located near the top of the motor and are used by the installer to check the water level or to top off if needed before installation.

Complete Corrosion and Water-Tight Protection

All main motor components are made of stainless steel: including the can housing (water tight type motors have baked epoxy coated carbon steel housings), shaft and bolts. All other motor parts are coated with the baked epoxy coating.

High-Quality Control

All Hitachi submersible motors are manufactured and tested under the most stringent quality control procedures in Japan, providing long service life and trouble-free operation.

High Thrust Bearing

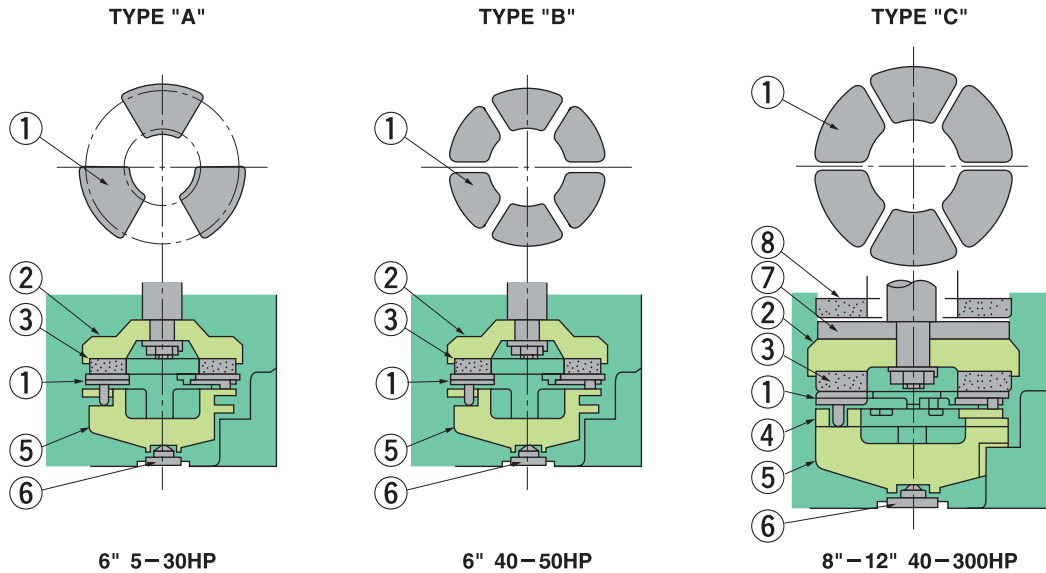

APPLICATION

Motor Size	Output 2P		Bearing Type	No. of Shoes
	HP	kW		
6"	5 - 30	3.7 - 22	A	3
6"	40 - 50	30 - 37	B	6
8"	40 - 150	30 - 110	C	6
10" - 12"	175 - 300	132 - 225	C	8

Number	Part Name
①	Pivot Shoe
②	Bearing Frame
③	Carbon Disc
④	Metal Support
⑤	Metal Frame
⑥	Thrust Plate
⑦	Slide Plate
⑧	Up Thrust Bearing

* HIGH-PERFORMANCE THRUST BEARING

The well established KINGSBURY design thrust bearing creates a wedge of water between the pivot shoe and carbon disc. Our innovative design permits high thrust loads to be placed on the bearings while showing no measurable wear after several years of severe duty operation. This allows for long pumping life, virtual trouble free operation and low maintenance. For all 6" motors, the 136kg. maximum continuous up-thrust is absorbed between the upper carbon sleeve bearing and the rotor balance ring. For all 8" - 12" motors, the 450kg. maximum continuous up-thrust is carried between the upper slide plate and the separate up-thrust carbon bearing.

Motor Size	2P			
	Down Thrust		Up Thrust	
	kg	lbs.	kg	lbs.
6" 5 - 30HP	1,590	3,500	136 *(200)	300 *(450)
6" 40 - 60HP	2,270	5,000	136 *(200)	300 *(450)
8"	4,540	10,000	450 *(680)	1,000 *(1,500)
10"	4,540	10,000	450	1,000
12"	4,540	10,000	450	1,000

Note :

1. Thrust ratings showed are continuous except for values marked*
2. *Momentary rating (3 minutes Max).

Canned Type

6" 1 ϕ 5-15HP (3.7-11kW)
6" 3 ϕ 5-50HP (3.7-45kW)

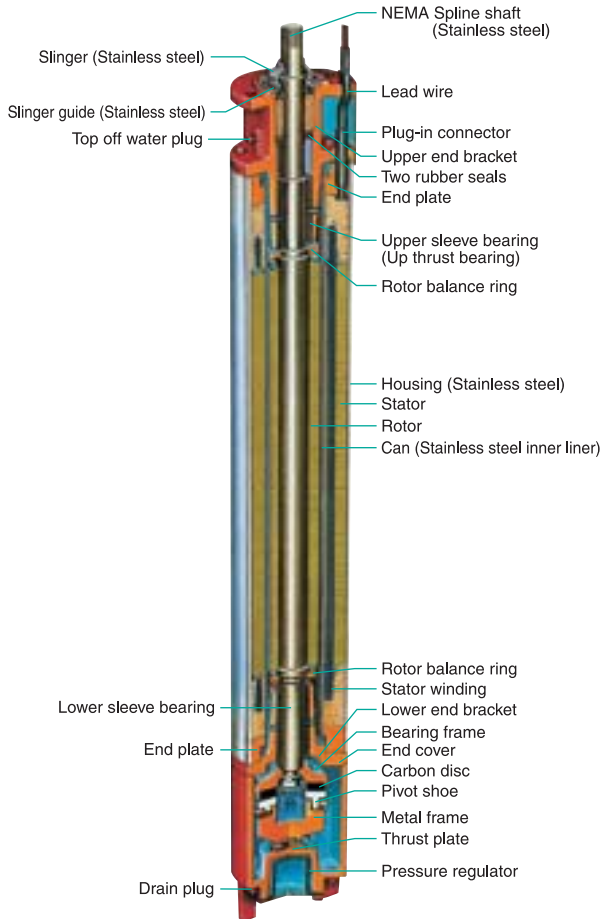

Model : VCTI-KK (AN)
VCTI-KQ (AN)

Standard Specifications

Cable Connection	Plug-in Type	
Cable Length	3.8m (150 inches)	
Shaft	NEMA Splined	
Flange	NEMA Standard	
Speed	3000 min ⁻¹	
Service Factor	1.0	
Voltage / Frequency	1 ϕ	230V 50Hz
	3 ϕ	415V 50Hz

Water Environment

Flow Rate	0.15 m/sec. (0.5 ft/sec.)	
pH Level	6.5-8.0	
Maximum Temperature	5-40HP	35°C (95°F)
	50HP	25°C (77°F)

Insulation

Construction	<p>Labels: Stainless steel frame, Coil, Epoxy resin mold, Stainless steel cylinder</p>
Slot Insulation	<p>Labels: Coil heat-resistant enamel wire, Slot insulation, Wedge, Stainless steel cylinder</p> <p>Class : E (6" 5-30HP) B (6" 40HP) F (6" 50HP)</p>

Size and Weight

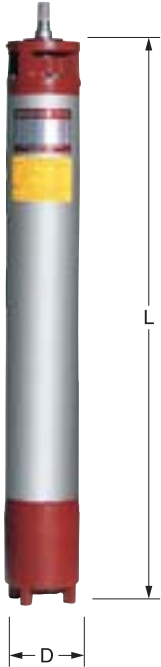

Motor Size	Phase	Output		D mm (inch)	L		Net Weight	
		HP	kW		mm	inch	kg	lbs.
6"	1 ϕ	5	3.7	140 (5.5)	685	26.97	50	110
		7.5	5.5		760	29.92	58	128
		10	7.5		760	29.92	58	128
		15	11		920	36.22	73	161
	3 ϕ	5	3.7		583	22.95	43	95
		7.5	5.5		630	24.80	45	99
		10	7.5		685	26.97	50	110
		15	11		760	29.92	58	128
		20	15		800	31.50	62	137
		25	18.5		920	36.22	73	161
		30	22		970	38.19	80	176
		40	30		1060	41.73	90	198
		50	37		1060	41.73	90	198

*Gross Weight : See page 10.

Cable Size and Type 3.8m (150 inches) Lead Wire Standard Length

Motor Size	Phase	Output		415V			230V		
		HP	kW	Lead Wire Size		AxB mm (inch)	Lead Wire Size		AxB mm (inch)
				mm ²	AWG		mm ²	AWG	
6"	1 ϕ	5-10	3.7-7.5	—	—	—	5.5	#10	25.1×9.6 (0.99×0.38)
		15	11	—	—	—	8	#8	27.7×10.4 (1.09×0.41)
	3 ϕ	5-40	3.7-30	5.5	#10	25.1×9.6 (0.99×0.38)	—	—	—
		50	37	8	#8	27.7×10.4 (1.09×0.41)	—	—	—

Cable Construction

Ethylene-Propylene Rubber Insulated Chloroprene
 Plug-in type (Field replaceable)
 Color Coded type
 (Blue, Brown, Black, Yellow/Green)

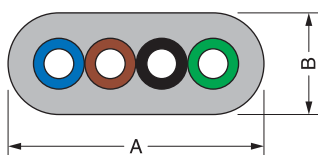

- Lead Wire : 600V class
- Chloroprene Cable

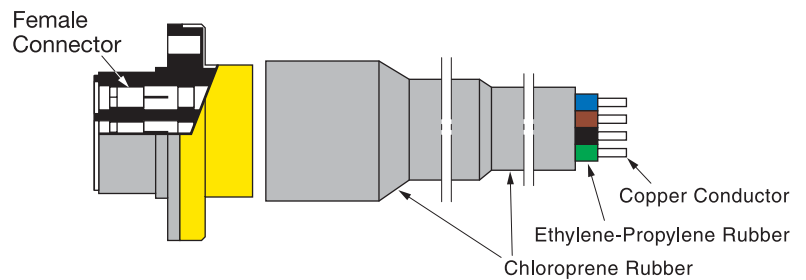

Water Tight Type

3 ϕ 40-300HP (30-225kW)

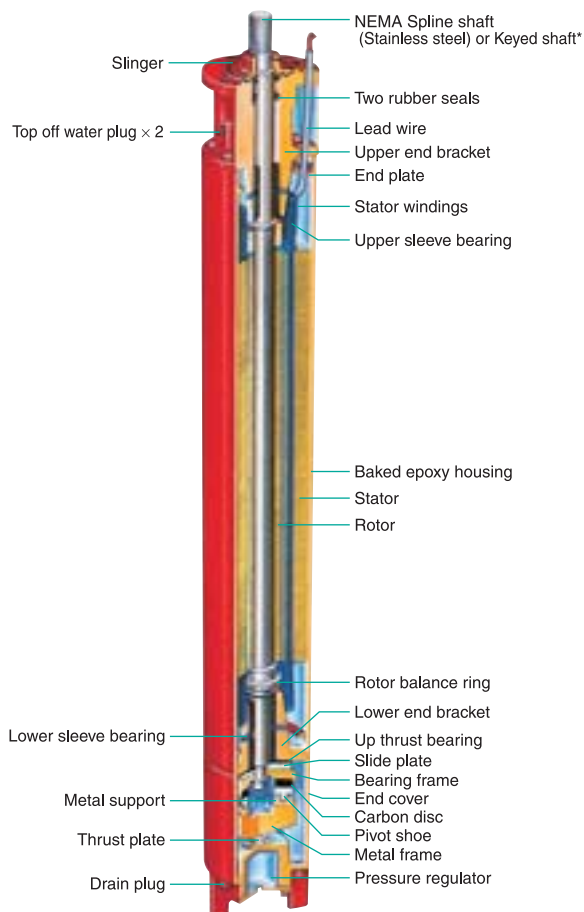

Model : VTI-KK (AN)

Insulation

Construction	
Slot Insulation	<p>Class : Y</p>

Description of Water Tight Insulation Wire

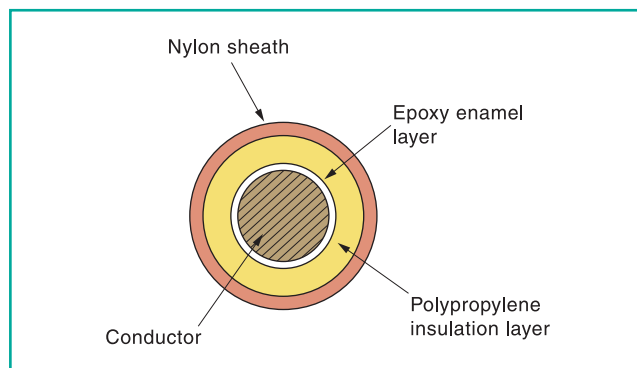

The reliability of submersible motors depends upon their insulation characteristics. Hitachi has carried out continuous research and development of submersible motors for many years, drawing upon its total corporate technology. These efforts have resulted in new patented water tight insulated magnet wire having excellent insulation characteristics. This patented technology is being applied to all Hitachi water tight submersible motors. For the insulation material, specially developed denatured polypropylene is applied over a special enamel layer. A teflon sheath is applied over this polypropylene layer for extra mechanical protection. These three insulation barriers are applied to copper conductors for complete insulation from the cooling fluid. This guarantees that Hitachi submersible motors will have an extremely long service life.

Standard Specifications

Cable Connection	Direct to Stator
Cable Length	5m (200 inches)
Shaft	Splined 40-150HP(30-110kW) Keyed 175-300HP(132-225kW)
Flange	NEMA Standard (See dimensions P9)
Speed	3000 min ⁻¹
Service Factor	1.0
Voltage/Frequency	415V 50Hz

Water Environment

Flow Rate	0.15 m/sec. (0.5 ft/sec.)
pH Level	6.5-8
Maximum-Temperature	25°C (77°F)

Size and Weight



Motor Size	Output		D mm (inch)	L		*Net Weight	
	HP	kW		mm	inch	kg	lbs.
8"	40	30	191 (7.52)	1180	46.44	160	353
	50	37		1250	49.19	185	408
	60	45		1350	53.15	210	463
	75	55		1480	58.27	235	518
	100	75		1680	66.14	270	595
	125	90		1680	66.14	270	595
	150	110		1780	70.08	300	661
10"	175	132	216.5 (8.52)	1770	69.68	370	816
	200	150		2020	79.53	430	948
	250	185		2020	79.53	430	948
12"	300	225	267.5 (10.53)	2000	78.75	660	1455

*Gross Weight : See page 10.

Cable Size and Type

5m (200 inch) Lead Wire Standard Length (Round 1 Stranded Conductor)

Motor Size	Output		Lead Wire Size		Cable Dia	
	HP	kW	mm ²	AWG	mm	inch
8"	40-60	30-45	8	#8	9.2	0.362
	75-125	55-90	14	#6	11.0	0.433
	150	110	22	#4	13.5	0.531
10"	175-250	132-185	30	#2	15.0	0.591
12"	300	225	60	#2/0	19.5	0.768

TYPE OF LEAD WIRE - 600V CLASS

Ethylene-propylene rubber insulated chloroprene cable.
Color coded type (Blue, Brown, Black, Yellow/Green)

Dimensional Data

6" VCTI-KK/VCTI-KQ 2 Pole

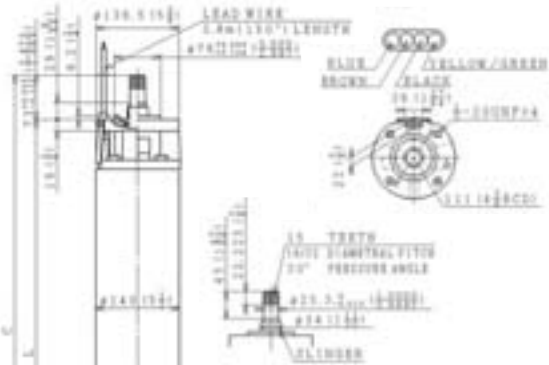

Type : VCTI-KK or KQ (AN)

Output		Phase	C		L	
HP	kW		mm	inch	mm	inch
5	3.7	1	758	29.84	685	26.97
7.5	5.5		833	32.79	760	29.92
10	7.5		833	32.79	760	29.92
15	11		993	39.09	920	36.22
5	3.7	3	656	25.82	583	22.95
7.5	5.5		703	27.63	630	24.80
10	7.5		758	29.84	685	26.97
15	11		833	32.79	760	29.92
20	15		873	34.37	800	31.50
25	18.5		993	39.09	920	36.22
30	22		1043	41.06	970	38.19
40	30	1133	44.60	1060	41.73	
50	37	1133	44.60	1060	41.73	

8" VTI-KK 2 Pole

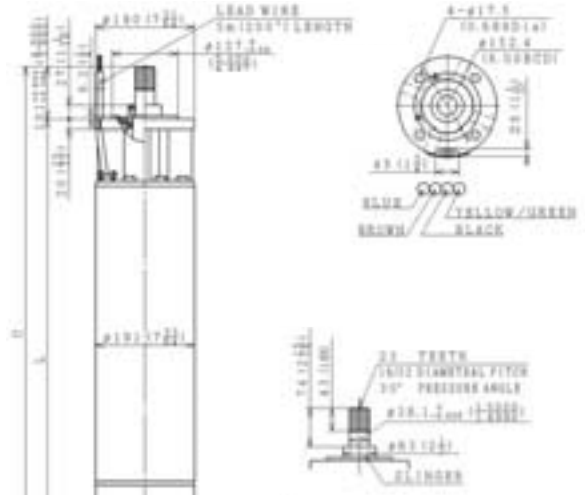

Type : VTI-KK (AN)

Output		Phase	C		L	
HP	kW		mm	inch	mm	inch
40	30	3	1281	50.44	1180	46.44
50	37		1351	53.19	1250	49.19
60	45		1451	57.13	1350	53.15
75	55		1581	62.24	1480	58.27
100	75		1781	70.12	1680	66.14
125	90		1781	70.12	1680	66.14
150	110		1881	74.06	1780	70.08

10" VTI-KK 2 Pole

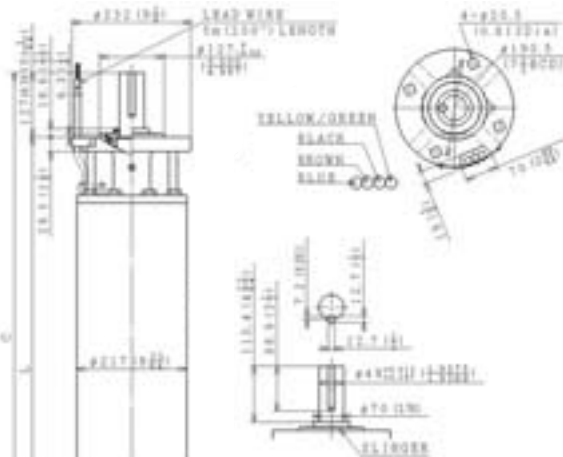

Type : VTI-KK (AN)

Output		Phase	C		L	
HP	kW		mm	inch	mm	inch
175	132	3	1897	74.70	1770	69.68
200	150		2147	84.55	2020	79.53
250	185		2147	84.55	2020	79.53

12" VTI-KK 2 Pole

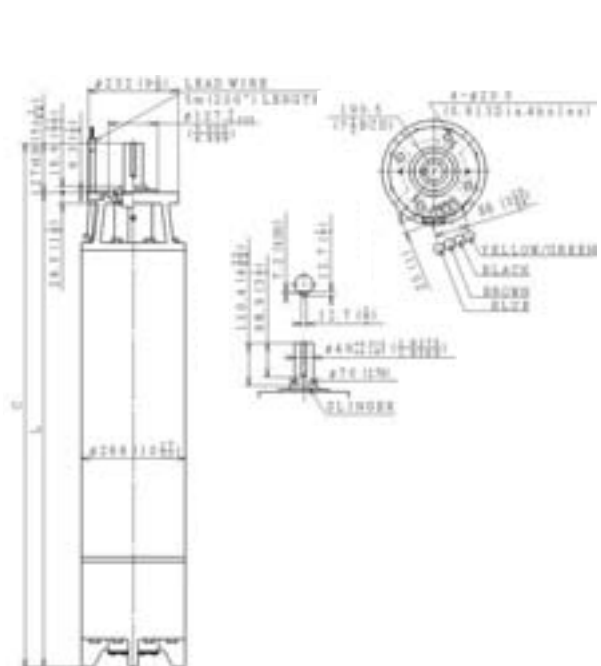

Type : VTI-KK (AN)

Output		Phase	C		L	
HP	kW		mm	inch	mm	inch
300	225	3	2127	83.75	2000	78.75

General Specifications

Motor Size	Flange Size	Motor Type	Output		Phase	Shipping Weight	
			HP	kW		kg	lbs
6"	6"	Canned	5	3.7	1	65	143
6"	6"	Canned	7.5	5.5		73	161
6"	6"	Canned	10	7.5		73	161
6"	6"	Canned	15	11		88	194
6"	6"	Canned	5	3.7		53	117
6"	6"	Canned	7.5	5.5		55	121
6"	6"	Canned	10	7.5		65	143
6"	6"	Canned	15	11		73	161
6"	6"	Canned	20	15		77	170
6"	6"	Canned	25	18.5		88	194
6"	6"	Canned	30	22		95	209
6"	6"	Canned	40	30		105	231
6"	6"	Canned	50	37		105	231
8"	8"	Water Tight	40	30		3	195
8"	8"	Water Tight	50	37	220		485
8"	8"	Water Tight	60	45	245		540
8"	8"	Water Tight	75	55	270		595
8"	8"	Water Tight	100	75	310		683
8"	8"	Water Tight	125	90	310		683
8"	8"	Water Tight	150	110	340		750
10"	10"	Water Tight	175	132	415		915
10"	10"	Water Tight	200	150	475		1047
10"	10"	Water Tight	250	185	475		1047
12"	12"	Water Tight	300	225	740	1631	

Today we manufacture more than 20,000 products-from ICs to electric power generation equipment. We are now one of Japan's largest and most reputable corporations, with consolidated annual sales over 65 billion dollars. HITACHI's motor design and manufacturing capabilities have grown along with the company's other diverse activities - reliable, high-quality, high-performance motors play an important part in maximizing industrial productivity. HITACHI motors reflect HITACHI's experience and technology as both a manufacturer and use of its own electric motors, an important reason why we can offer higher efficiency and profitability for your operations - by using our product ... as we do.



PRODUCTION PLANT (NARASHINO JAPAN)



HITACHI ADMINISTRATIVE DIVISION



HITACHI CENTRAL RESEARCH LABORATORY

Information in this brochure is subject to change without notice.

For further information, please contact your nearest sales representative.

 **Hitachi Industrial Equipment Systems Co., Ltd.**